

## OPTIMEDIA

## INSTRUCTION SHEET

### Optimedia Bin Rail

*Please read these instructions carefully and follow the installation steps in sequence.*

#### Tools Required

-Phillips Head Screwdriver

Space required is 6.25" which provides 1.00" of clearance.

1. Place the Mounting Brackets in the selected position. They mount by inserting the tabs into slots, turned so the square holes are to the rear. Drive (2) #10-24 x.37 screws into the holes at the brackets front.

2. Repeat for the one opposite, making sure they are at the same level.

3. Attach the Bin Rail by inserting the hooks into the square holes of the brackets. **Secure it** by driving a #10-24 x.37 screw through the Rail, using the hole just below the first hook, both sides.



Bin Rail

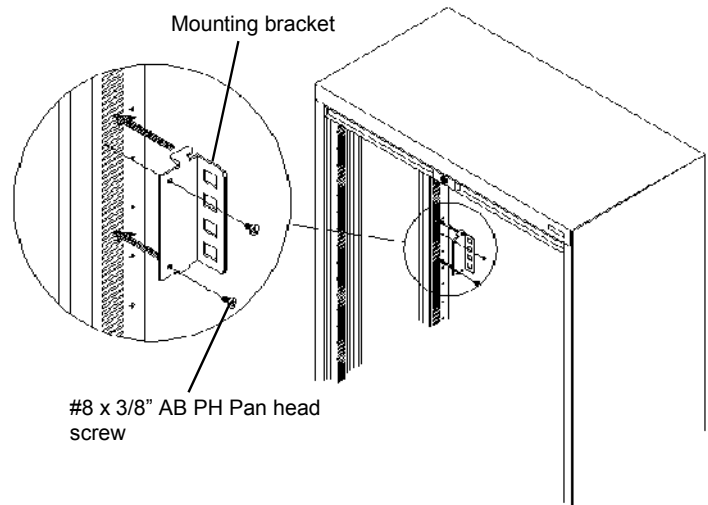

Figure 1

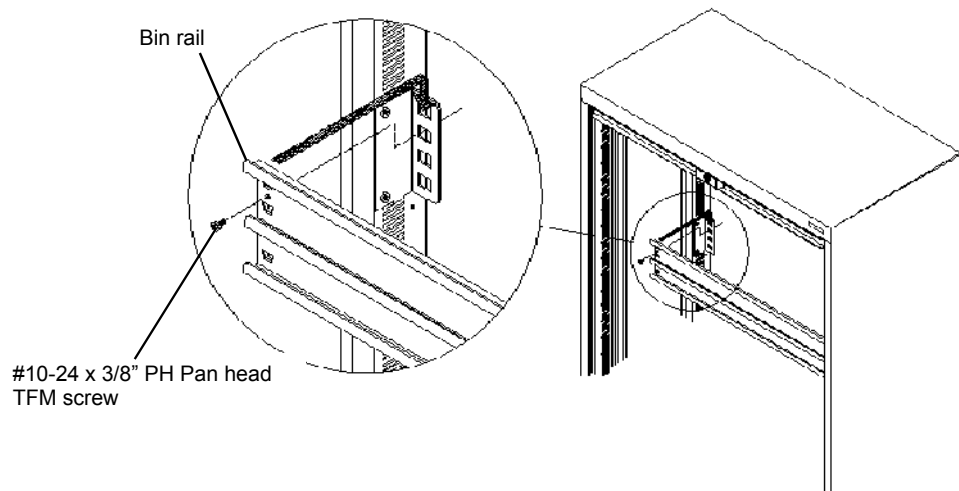

Figure 2

	PART NO.	DESCRIPTION	QTY/UNIT
1	4947X	BIN RAIL	1
2	4948X	MOUNTING BRACKET	2
3	66714	#10-24 x 3/8" PH PAN HEAD TFM SCREW	2
4	18773	#8 x 3/8" AB PH PAN HEAD SCREW	4

